

**C**  
**101** PLAN : VILLAGE SQUARE  
RC Seating 1: 50

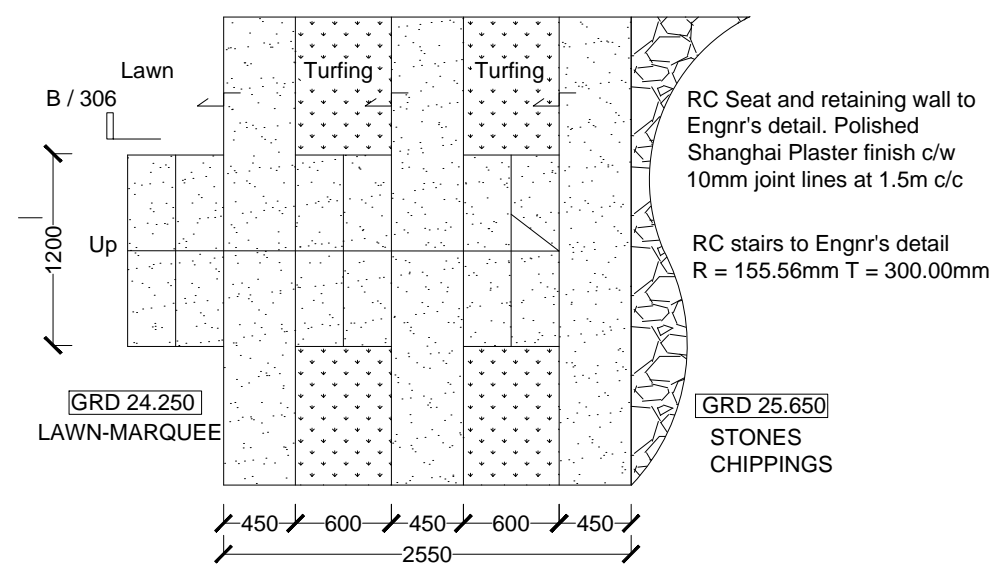

**A**  
**101** PLAN : Pool Deck  
Terraces down to Lawn-Marquee 1: 50

**D**  
**306** DETAIL : VILLAGE SQUARE  
RC Seating - Section 1: 50

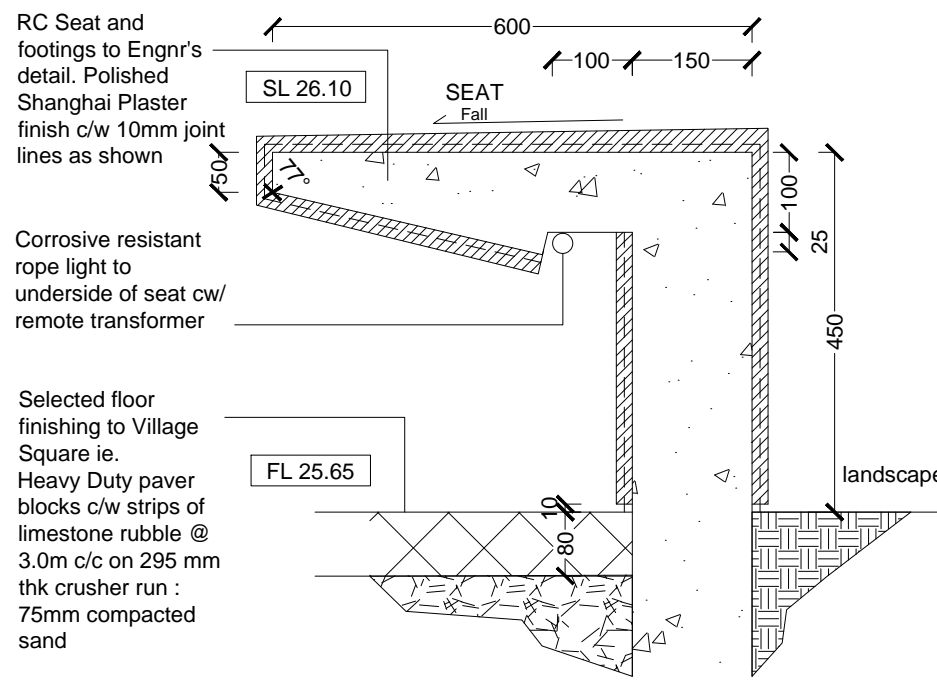
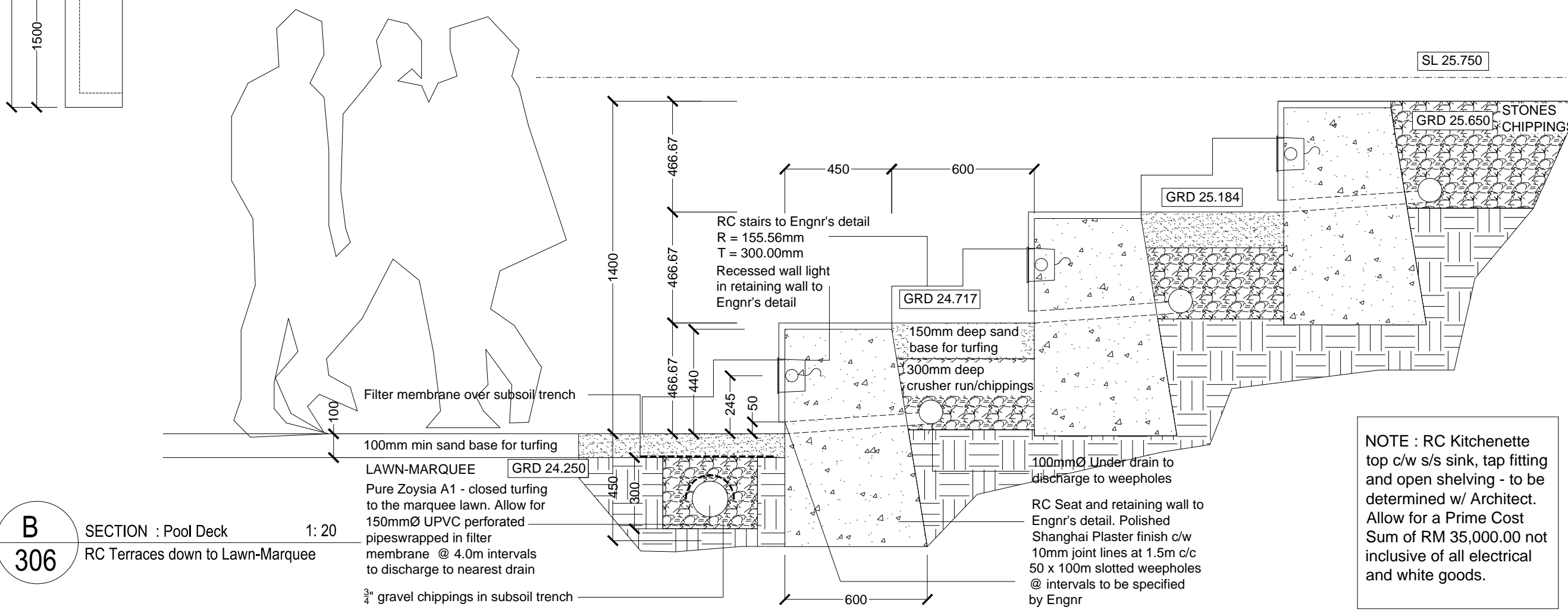

**B**  
**306** SECTION : Pool Deck 1: 20  
RC Terraces down to Lawn-Marquee

**NOTE :** RC Kitchenette top c/w s/s sink, tap fitting and open shelving - to be determined w/ Architect. Allow for a Prime Cost Sum of RM 35,000.00 not inclusive of all electrical and white goods.